



CPC - CPL



according to norm EN 453 rev. 2015

Volumetric Divider

Automatic volumetric Vacuum divider with 1 or 2 pistons. CPC model with belt without rounding channel, CPL model with belt and with rounding channel (1 or 2). Machine with a production of dough pieces up to 1650 grs. with one piston or 370 grs with two pistons.

Machine can work any kind of dough with hydration up to 100% as well as low hydration (around 55%) with pressure hopper (optional). Machines is suitable for intensive use, up to 2400 pcs/h. (1 piston) or 4800 pcs/h (2 pistons) with an excellent weight accuracy.

Standard Features

- Stainless steel cylinder
- Electronic speed regulation
- Electronic weight adjustment
- 30 kg hopper with Teflon coating
- Independent motorized conveyor belt
- Petrol green ribbon
- Electronic piece counter
- Power supply 400 volts/3PH/50-60Hz
- Stainless steel casing
- Single cylinder divider 900/2400 pcs/h
- Twin cylinder divider 1800/4800 pcs/h
- One channel rounding device (only on model CPL 1P)
- Two-channel rounding device (only on model CPL 2P)

Option and cutting rollers

- "AI" touch screen with fixed Arm
- Swivel Arm for Touch Screen
- Belt Scraper
- Pressure hopper
- Roller Extractor at the end of the cylinder
- Flour duster with adjustment of the quantity of flour released
- Additional lubrication for drum with tap
- "Start and stop" pushbutton panel for remote control and power take-off
- Belt Speed variator
- Compressed air extraction system
- Two-channel rounding device (standard on mode. CPL 2P)
- Long mould table (3120x490) (only on mode CPL 1P)
- Connectable
- Different capacity Hopper with teflon coating

MODELS

CPC 1 P	1 Piston divider with belt (1050x277 or 2120x277 or 2480x277) without pre-rounding device
CPC 2P	2 Pistons divider with belt (1050x277 or 2120x277 or 2480x277) without pre-rounding device
CPL 1P	1 Piston divider with belt (2120x490) with pre-rounding device (900 mm.)
CPL 2P	2-piston divider with belt (2120x490) with double pre-rounding device (2x 900 mm)
CYLINDER SIZE (mono/bi-cilindrical)	1 piston with Ø 60-80-100-110-120-130-140-150 mm. or 2 pistons with Ø 60-80 mm
HOPPER	30-80-120-160-200-250-300 kg
PRESSURE HOPPER	160-200-250-300 KG.



MODELLO/ MODEL		DIMENSIONI/ DIMENSIONS CPC/CPL	PESO MACCHINA WEIGHT CPC/CPL	Ø PISTONE PISTON Ø	PEZZATURA WEIGHT		PEZZI/ORA HOUR PRODUCTION		
				mm	min	max	min	max	
CPC CPL	626x1671x1501 733x1671x1501	450 500	Ø 60	20	220	900	2400	900	2400
			n° 2 Ø 60						
			n° 2 Ø 80	30	370	1800	4800		
			Ø 80						
			Ø 100	50	700	900	2400		
			Ø 110	70	850				
			Ø 120	90	1000				
			Ø 130	130	1200				
			Ø 140	170	1400				
			Ø 150	200	1650				

MODELLO/ MODEL	POTENZA MOTORE	POTENZA MOTORE	FREQUENZA DI FUNZIONAMENTO / OPERATING FREQUENCY	ALLACCIAMENTO ELETTRICO/ POWER SUPPLY PALLWEIGHT
CPC	2.2	0.25	50/60 HZ	400V 3PH+N+Gr with five-pole plug 16A
CPL	2.2	0.25	50/60 HZ	

STANDARD



STANDARD ELECTROMECHANICAL



TOUCH SCREEN
PANEL
OPTION



SCRAPER
OPTION

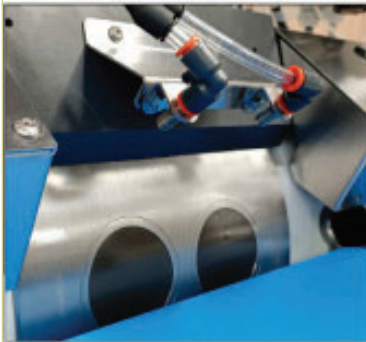

COMPRESSED AIR
EXTRACTION SYSTEM
(OPTION)

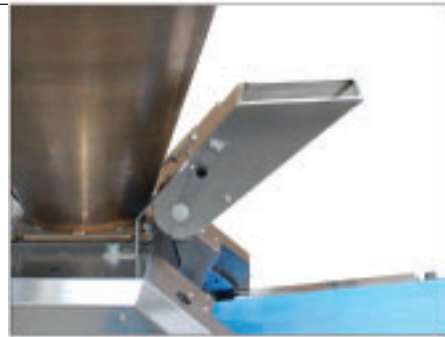

SFARINATORE
(OPTION)



N.B.
THE PHOTOS INDICATED
ABOVE ARE TO BE
CONSIDERED WITH THE COLOR
OF THE CARPET
PRESENT IN THE IMAGE ON
THE LEFT

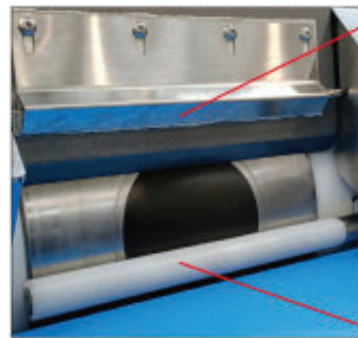

ADDITIONAL
LUBRICATION FOR THE
DRUM
(OPTION)

EXTRACTOR
ROLLER
(OPTION)



MOTORIZED DOUBLE
PRE-ROUNDING
TABLE. 2120x490 mm
(900 mm. pre-rounding
device)



MOTORIZED
ROUNDER TABLE
3120x490 mm
(1400mm pre-rounding
device)

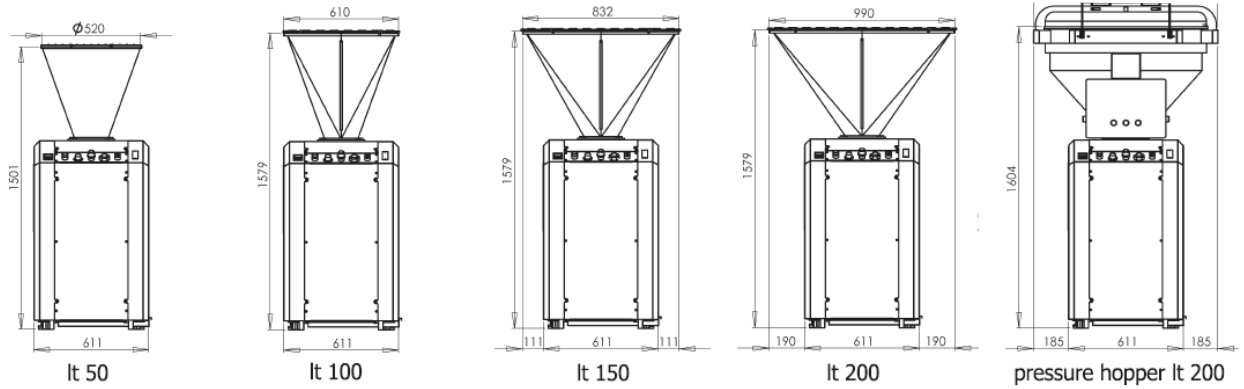

STANDARD CPC MODEL

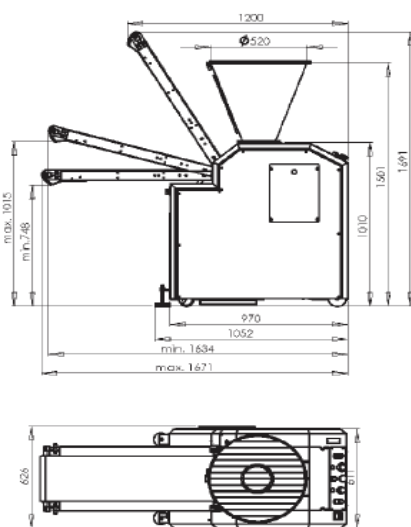

Standard belt 2120 x 277 mm or long belt 2480 x 277 mm

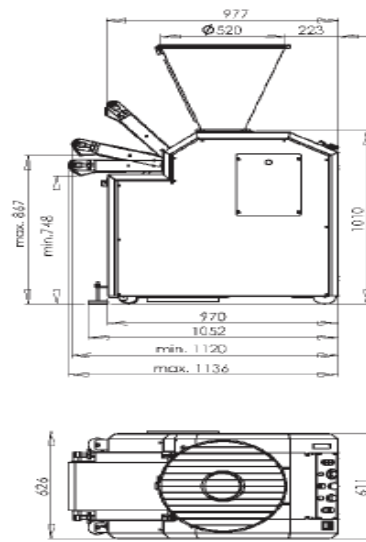

Short belt 1050 x 277 mm or 1312 x 277 mm

STANDARD CPL MODEL

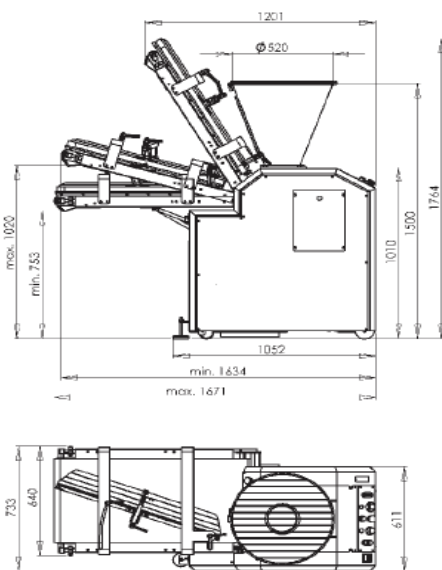

Rounding device 90 cm with belt 2120 x 490 mm

OPTION CPL MODEL WITH LONGER BELT

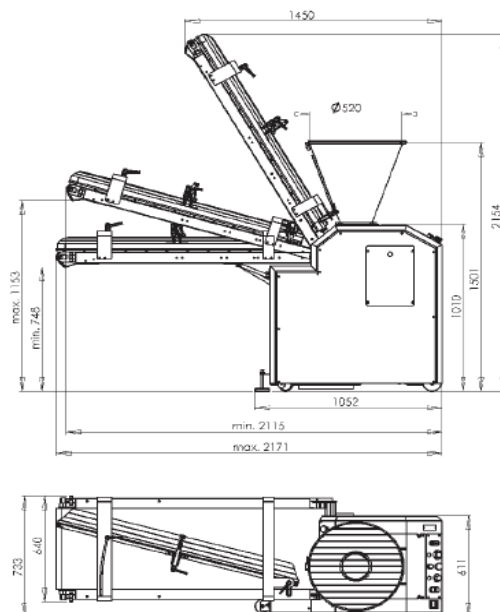

Rounding device 140 cm with belt 3120 x 490 mm

Properties of Esmach Ali Group S.r.l. - reproduction prohibited



CPL MAXI



according to norm EN 453 rev. 2015

Volumetric Divider

Vacuum divider with two or four pistons equipped with parallel rounding channels for a production of dough pieces up to 1200 grs. with two pistons or 360 grs with four pistons. Machine can work any kind of dough with hydration up to 100% as well as low hydration (around 55%) with pressure hopper (optional). Machines is suitable for intensive use, up to 4000 pcs/h. (2 pistons) or 8000 pcs/h (4 pistons) with an

Standard Features

- Stainless steel cylinder
- Electronic speed regulation
- Electronic weight adjustment
- 130 Kg hopper with Teflon coating
- Independent motorized conveyor belt
- Petrol green ribbon
- Electronic piece counter
- Power supply 400 volts/3PH/50-60Hz
- Stainless steel casing
- Two cylinders model 1800/4000 pcs/h
- Four cylinders model 3600/8000 pcs/h
- Two channel rounding device (only on model CPL 2P)
- Four channel rounding device (only on model CPL 4P)

Option and cutting rollers

- "AI" touch screen with fixed Arm
- Swivel Arm for Touch Screen
- Belt Scraper
- Pressure hopper
- Roller Extractor at the end of the cylinder
- Flour duster with adjustment of the quantity of flour released
- Additional lubrication for drum with tap
- "Start and stop" pushbutton panel for remote control and power take-off
- Belt Speed variator
- Compressed air extraction system
- Connectable
- Different capacity Hopper with teflon coating

MODELS

CPL MAXI 2P	2-pistons divider with belt (2120x610) with two pre-rounding channels (2x 900 mm)
CPL MAXI 4P	4 pistons divider with belt (2120x760) with four pre-rounding channels (4x900 mm.)

OPTIONS

CYLINDER SIZE	Ø 100-110-120-130 150 mm. for two pistons divider; and Ø 60-80 mm for four pistons divider
HOPPER	130-160-200 kg
PRESSURE HOPPER	160-200-250-300 kg



MODELLO/ MODEL		DIMENSIONI DIMENSIONS	PESO MACCHINA WEIGHT	Ø PISTONE PISTON Ø	PEZZATURA WEIGHT		PEZZI/ORA HOUR PRODUCTION	
				mm	min	max	min	max
CPL MAXI	2P	909x1716x1582	500	n° 2 Ø 100	50	700	1800	4000
				n° 2 Ø 110	70	850		
				n° 2 Ø 120	90	1000		
				n° 2 Ø 130	130	1200		
CPL MAXI	4P	909x1716x1582	750	n° 4 Ø 60	20	220	3600	8000
				n° 4 Ø 80	30	370		

MODELLO/ MODEL	POTENZA MOTORE	POTENZA MOTORE	FREQUENZA DI FUNZIONAMENTO / OPERATING FREQUENCY	ALLACCIAMENTO ELETTRICO/ POWER SUPPLY PALLWEIGHT	PESO/ WEIGHT
CPL MAXI 2P	2.2	0.25	50/60 HZ	400V 3PH+N+Gr with five-pole plug 16A	500
CPL MAXI 4P	2.2	0.25	50/60 HZ		750

STANDARD



STANDARD ELECTROMECHANICAL TIMER



TOUCH SCREEN
PANEL (OPTION)



SCRAPER
(OPTION)



Properties of Esmach Ali Group S.r.l. - reproduction prohibited



COMPRESSED AIR
EXTRACTION SYSTEM
(OPTION)



FLOUR DUSTER
(OPTION)



N.B.
THE PHOTOS INDICATED
ABOVE ARE TO BE
CONSIDERED WITH THE COLOR
OF THE CARPET
PRESENT IN THE IMAGE ON
THE LEFT

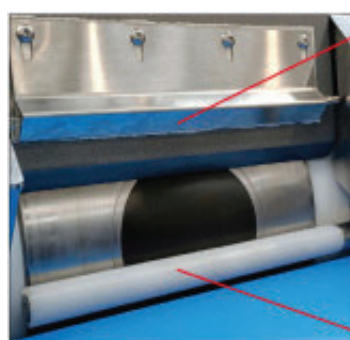

ADDITIONAL
LUBRICATION FOR THE
DRUM
(OPTIONAL)

EXTRACTOR
ROLLER
(OPTIONAL)



MOTORIZED DOUBLE
PRE-ROUNDING
TABLE. 2120x500 mm
(900 mm. pre-rounding
device)



MOTORIZED
ROUNDER TABLE
3120 mm (1400mm
pre-rounding device)

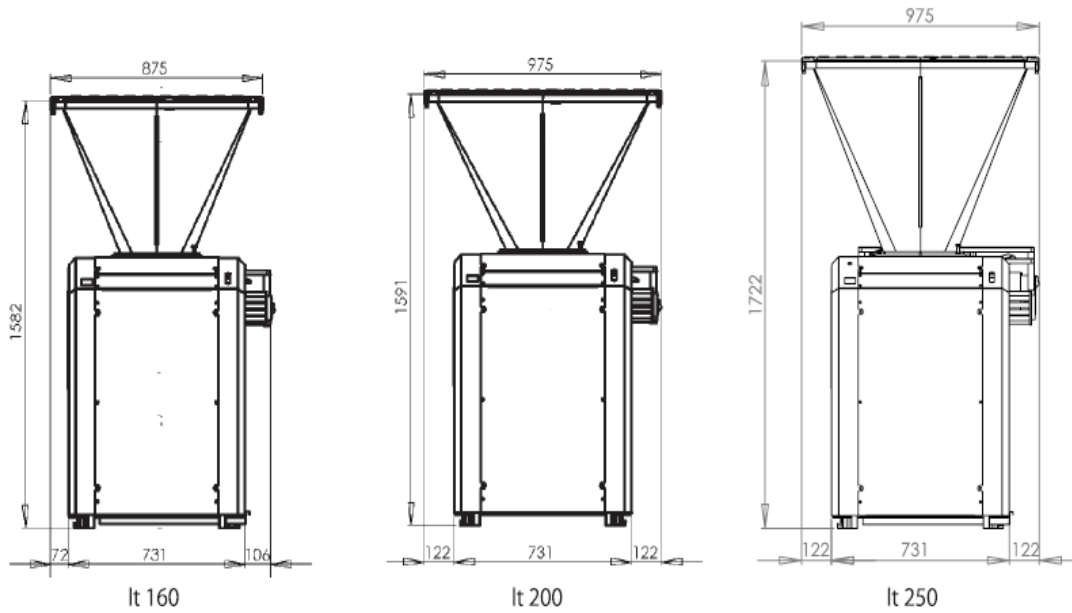

CPL MAXI 2 P

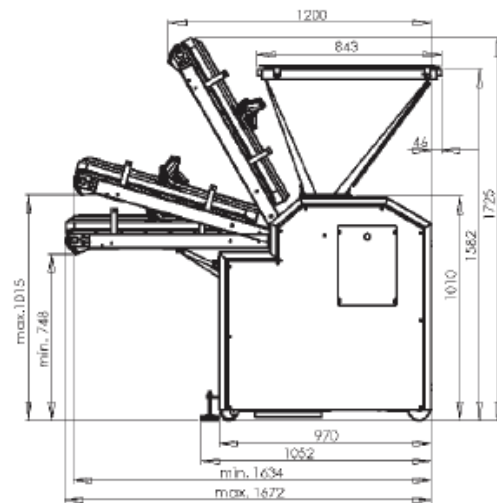

CPL MAXI 4 P

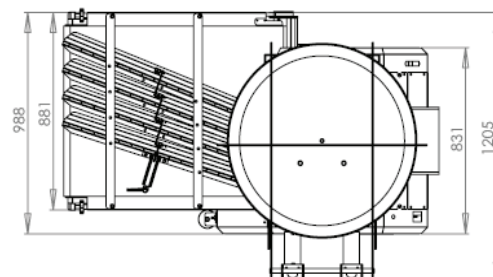
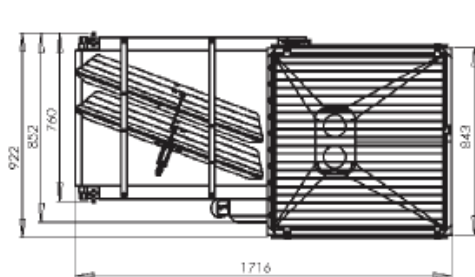
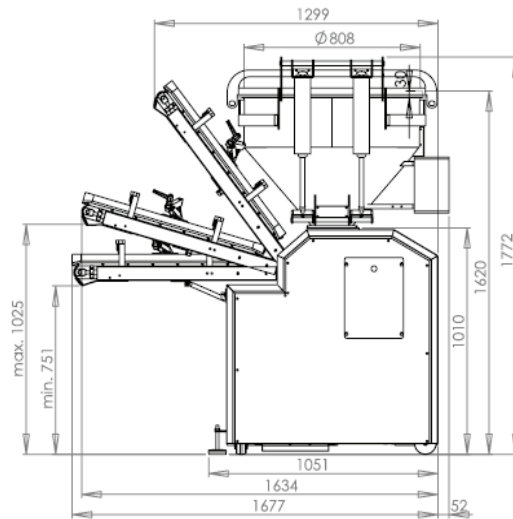

Properties of Esmach Ali Group S.r.l. - reproduction prohibited