



# EB/FL 2/3P



## Retarder/proofer/proofing bench for bread and pizza

The EB/FL are stainless steel retarder-proofer and automatic programmed proofing tables. They are used for the programmed and deferred proofing of bakery and pizzeria products. They are available in two- or three-module/door versions, with a single shelf.

### Features

Retarder-proofer tables equipped with a monoblock unit with ventilated refrigeration, designed to meet the requirements of climate class 5 (tropicalized). The system features an easily removable unit, facilitating maintenance and replacement. The evaporator is treated with cataphoresis paint, while defrosting is automatic via a digital controller. The system includes internal ventilation modulation and a display that constantly shows the humidity percentage, maintained at an optimal level thanks to a humidifier controlled by an internal probe.

The product cycle is divided into 7 operational phases:

1. Cooling and stabilization
2. Storage
3. Product awakening
4. First leavening phase
5. Second leavening phase
6. Third leavening phase
7. Delayed baking

### Operating principle

A corrosion-resistant coil made of AISI 316 low-carbon steel is used to manage condensation water. The doors are equipped with self-closing mechanisms and a fixed 100° opening system for easy access. The seven-chamber magnetic seal is easily removable for cleaning and maintenance.

The table is equipped with a 7" capacitive touchscreen display, ensuring easy interaction with settings.

### Construction

The structural elements, such as the adjustable feet in AISI 304 stainless steel and the perforated guides and adjustable and removable racks in AISI 304 stainless steel, ensure robustness and versatility.

BANCO FERMALIEVITA	EB/FL 2P E 3P
Interior fittings	AISI 304 stainless steel guides and racks - Adjustable and removable.
Racks included	Not included
LED strip	<b>Not available</b>
WiFi kit	▪
Key lock	<b>Not available</b>
Air distribution duct	▪
Door opening pedal	▪
Wheel kit	<b>Not available</b>
Cable with Schuko or UK plug	▪ (Schuko)
Diamond-cut bottom with drain hole	▪
▪ <b>Standard</b>   □ <b>Optional</b>   □ <b>€ Paid Optional</b>	



**Technical features**

**MODELS**

**EB/FL2P**

**EB/FL3P**

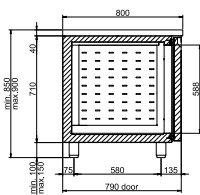
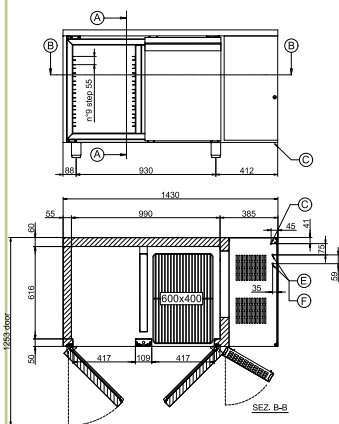

SEZ. A-A

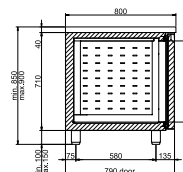
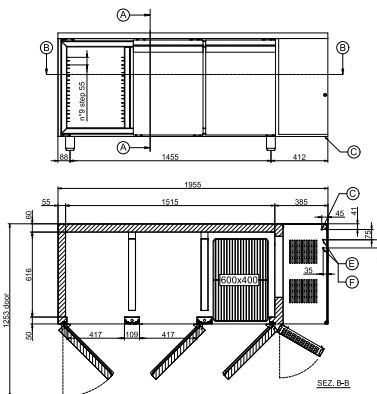

SEZ. A-A

**TECHNICAL DATA**

		EB/FL2P MOD. WITH 2 DOORS	EB/FL3P MOD. WITH 3 DOORS
		bread - pastry	bread - pastry
Capacity		Maximum set-up capacity N.9 (step 55 mm) x door - EN 600x400	Maximum set-up capacity N.9 (step 55 mm) x door - EN 600x400
Pairs of slides	n°/No.	included N.4 "L" x door - EN 600x400	included N.4 "L" x door - EN 600x400
Dimensions WxDxH	mm	1430x800x850-900	1955x800x850-900
Packaging WxDxH	mm	1470x830x1100	1995x830x1100
Net weight	kg	106	134
Gross weight	kg	127	160
Temperature	°C	(-5/+35)	(-5/+35)
Energy class		-	-
Gross volume	L	388	593
Net refrigeration volume	L	260	389
Climate class		5 +40°C / 40% R.H.	5 +40°C / 40% R.H.
Refrigerant gas		R290	R290
Defrosting		ELECTRIC	ELECTRIC
Condensation evaporation		Condensate evaporation via a corrosion-resistant coil in AISI 316 low carbon steel.	Condensate evaporation via a corrosion-resistant coil in AISI 316 low carbon steel.
Humidity	%	65-95%	65-95%
Condensation		AIR	AIR
Refrigeration capacity	W	520	520
Supply voltage	Volt	AC230V 1N+T 50Hz	

**LEGENDA MODELLI DI BANCHI FERMALIEVITA/LEGEND OF MODELS OF RETARDER PROOFING BENCHES**

EB/FL		2P 2 doors	L Smooth worktop
Esmach RETARDER PROOFING bench	P Bread - pastry	3P 3 doors	A Worktop with upstand
		4P 4 doors	